

# Fast Switching Pockels Cell Driver for SLR Laser System

by

J. Kölbl<sup>a</sup>, M. Fröschl<sup>a</sup>, A. Seedsman<sup>a</sup>, Y. Gao<sup>b</sup>, M. Dawson<sup>b</sup>

<sup>a</sup>EOS Optronics GmbH, Ulrichsberger Str. 17, D-94469 Deggendorf, Germany

<sup>b</sup>EOS Space Systems, 111 Canberra Avenue, Griffith ACT 2603, Australia

October 2008

## 1. Abstract

The presented research was concentrating on the development of ultrafast Pockels cell driver for ultrafast, high repetition rate and high energy Laser system. Pockels cells can be used for regenerative amplifier, pulse slicer (pulse picker), and other fast optical switching system in SLR Laser and other types of Laser systems.

The devised driver electronics for the actual Pockels cell is specifically characterized that two Pockels cells can be connected and simultaneously driven with a fast slope of 9.5 kV in less than 11 ns, even at high Laser repetition rates of up to 2 kHz. By using a push-pull switching arrangement, a variable and low-jitter impulse width from 80 ns to 2.3  $\mu$ s is achieved. Due to the drive capability of the circuit, more than one Pockels cell can be cascaded whilst maintaining very fast switching performance.

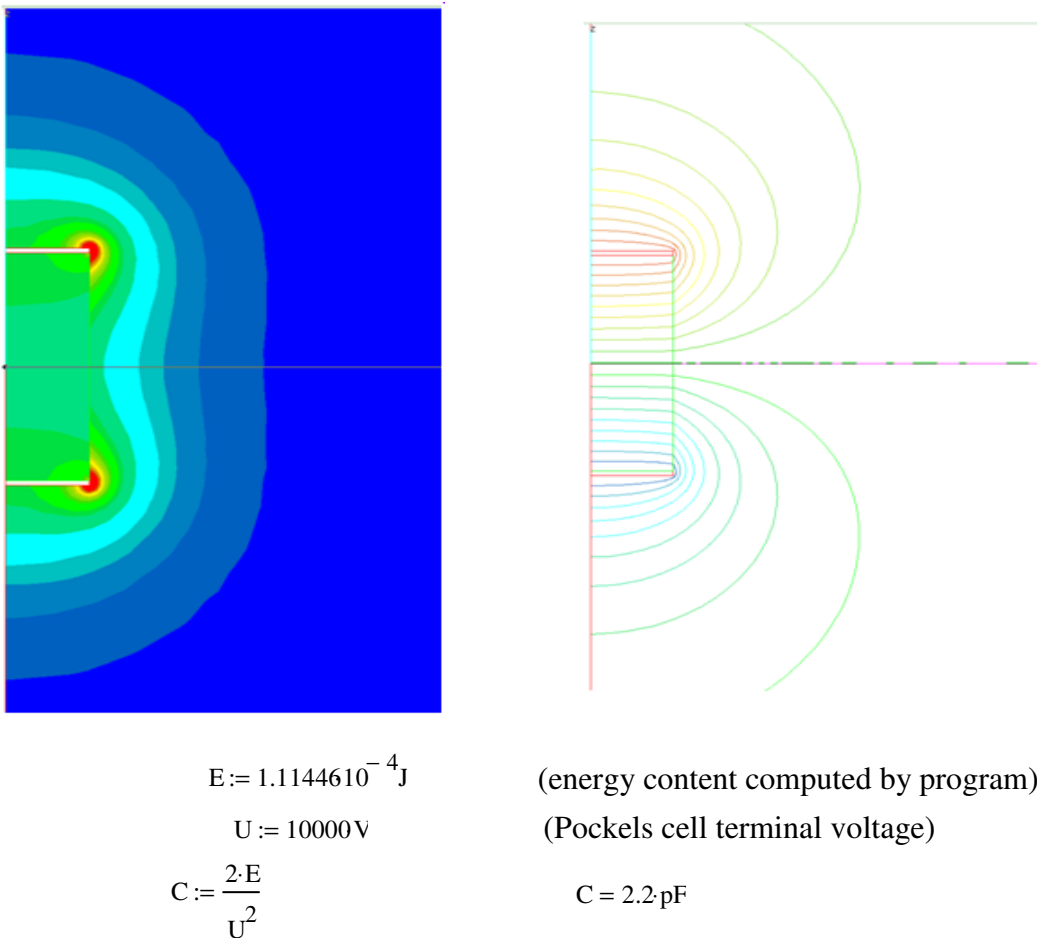
## 2. Pockels Cell

Pockels cells for ultrafast, high repetition rate, and high energy Laser systems require the electro-optic crystal material exhibit virtually no piezo-electric effect with electrical signals between DC and 100 kHz; there should be no ringing superimposed on the transmitted optical beam passing through the crystal so the Pockels cell can be utilized with high energy Lasers operating at high repetition rates; having a useful optical wavelength range from 350 nm to 4300 nm. For these reasons Rubidium Titanyl Phosphate -  $\text{RbTiOPO}_4$  (RTP) is normally selected as the electro-optic crystal material for the Pockels cell. Unfortunately only a few companies in the world can grow good quality RTP crystals, and at the present time 7.5 mm diameter RTP based Pockels cell is the largest diameter that can be sourced commercially. Pockels cells with this size are not large enough for many of our high repetition rate and high energy Lasers.

New Beta Barium Borate ( $\text{b-BaB}_2\text{O}_4$ , or BBO) crystal based Pockels cells have been developed by EOS. BBO crystals can be grown at a much larger size than RTP. Furthermore, BBO crystal has a higher transmittance and lower insertion loss at visible and infrared wavelength regions, and a higher damage threshold than RTP. 8 mm, 12 mm, and 14 mm diameter Pockels cells have been designed, and developed. So far 8 mm and 12 mm Pockels cells have been assembled, tested, and used in our Laser systems successfully. All the design specifications have been achieved. These Pockels cells exhibit negligible piezo-electric ringing effect at repetition rate up to 10 kHz. These are some of the world's largest Pockels cells for ultrafast, high repetition rate and high-energy laser applications.

Testing of 14 mm BBO based Pockels cell is still in progress. The driver electronics for the Pockels cell is specifically characterized that two Pockels cells can be connected and simultaneously driven with a fast slope of 9.5 kV in less than 11 ns, even at high Laser repetition rates of up to 2 kHz.

Pockels cells are high-voltage controlled wave plates. As the speed of changing states of the cell is quite important from a Laser system point of view, the terminal capacitance together with the quarter wave voltage are the key specifications. As the actual Pockels cell is an expensive device, an emulation device (high voltage capacitor) is used for development process of the driver electronics. It was found that the classical plate's capacitor formula can be used to estimate the Pockels cell's capacitance. An electromagnetic simulation is performed to verify that the capacitor's formula can be applied. As shown in Figure 1, the Pockels cell simulated capacitance yields 2.2 pF, whereas the popular capacitor's formula yields 1.8 pF.

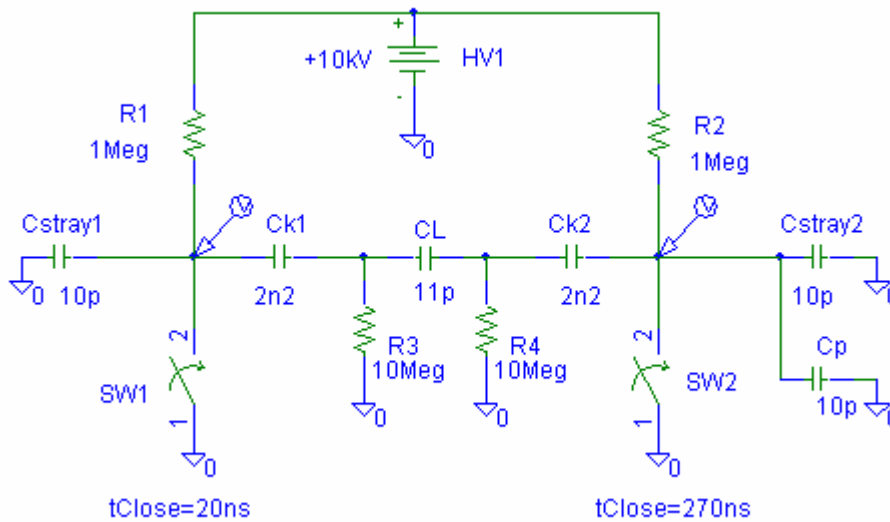


**Fig. 1:** Field simulation using finite element computation to find equivalent Pockels cell's capacitance and compare to classical capacitor formula

The field simulation requires the circular equivalent (radius of 10.55 mm) of the rectangular plates (14 mm x 25 mm) in order to model the electrical field. Finally, the energy content of the system is calculated. A voltage difference of 10 kV is used to compute the capacitance.

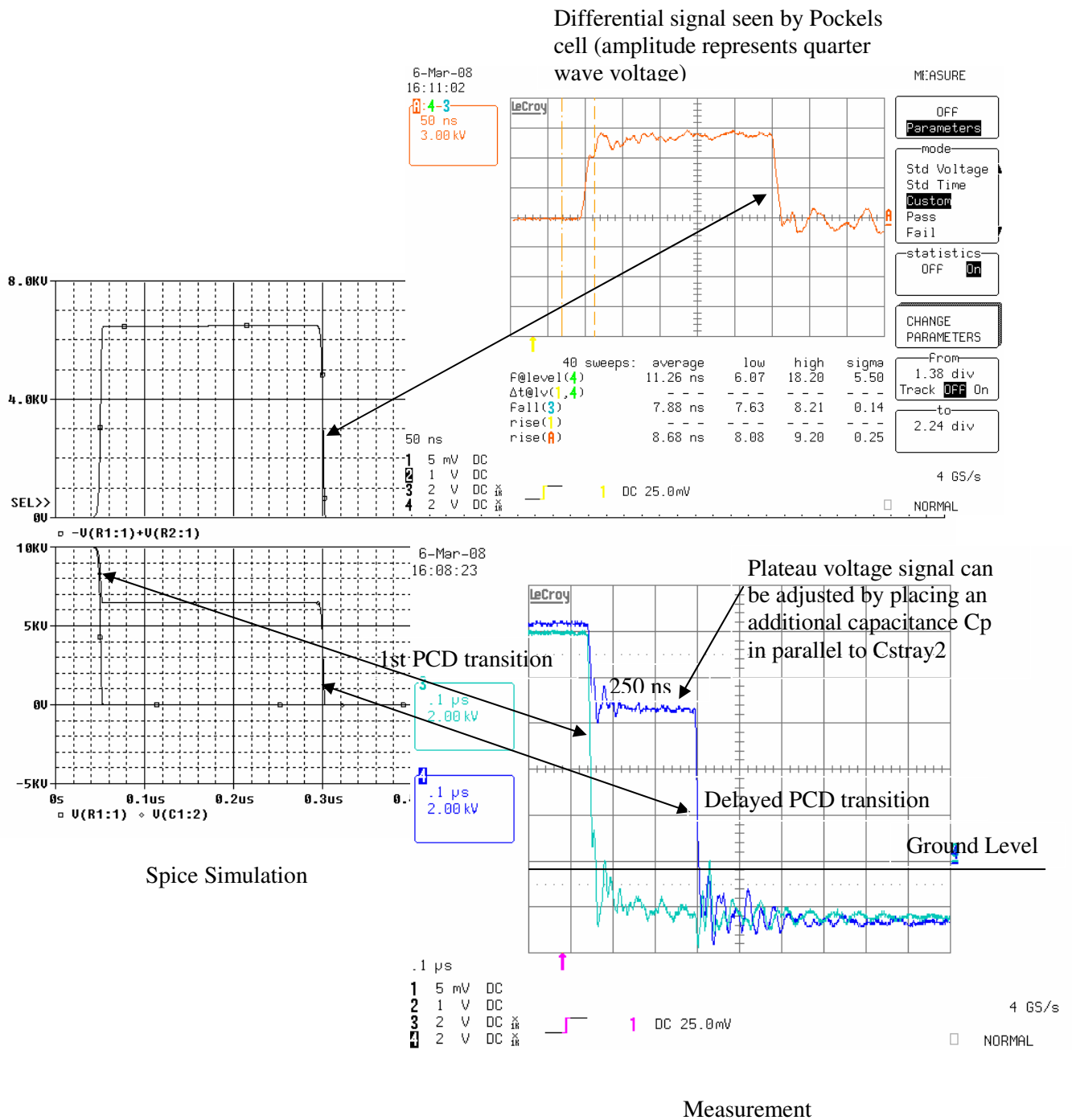
### 3. Pockels Cell Driver Electronics

As shown in Figure 2, the basic switch consists of two very fast switches. Switch SW1 closes first, whereas switch SW2 closes after a variable delay (250 ns as example in Figure 2), which is forming a push-pull arrangement. The delay generator is implemented in a separately shielded analogue electronics assembly to prevent electromagnetic interference.



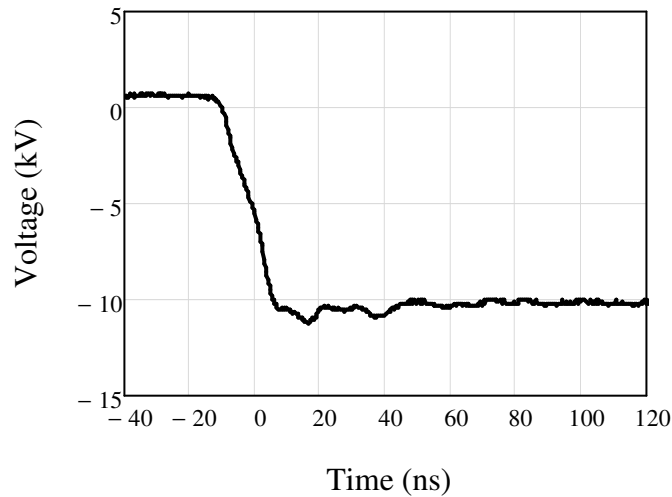
**Fig. 2:** Basic topology of Pockels cell push-pull switching arrangement (CL is actual Pockels cell crystal, delay setting is 250 ns)

The delayed switch in Figure 2 is variable by means of a potentiometer. The delayed switching is required to provide a differential impulse seen by the Pockels cell load. The circuit theory shows that the capacitances (labelled Cstray1 and Cstray2) are critical in combination with the load capacitance. It is found that even an additional capacitor (Cp) needs to be placed in parallel to Cstray2 in order to adjust the plateau signal voltage as shown in Figure 3, as it acts as capacitive voltage divider. The simulation and measurement results are compared against each other as shown in Figure 3.

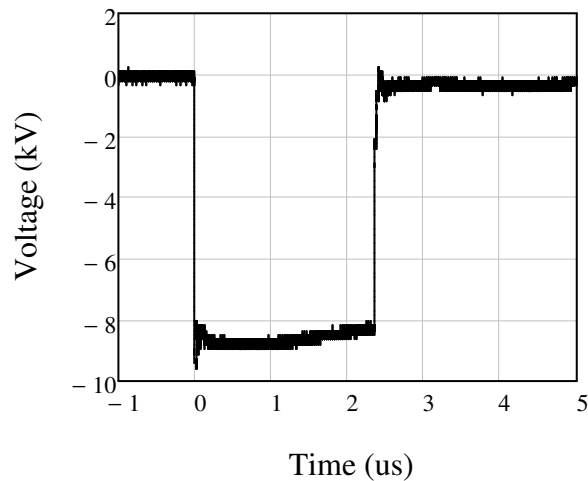


**Fig. 3: Comparison of Simulation and Measurement**

By using a standard measurement probe (model type TT-HVP 15HF from company Testec) with 50 MHz bandwidth (7 ns rise time), 1 pF capacitance and 100 M $\Omega$  impedance, the transition of the final Pockels cell driver device was measured as shown in Figure 4 and Figure 5.



**Fig. 4:** Typical fall time with a load capacitance of 11 pF, probe's capacitance not included (< 11 ns for 20 % - 80 % criteria)



**Fig. 5:** Differential probe measurement with 2 probes of maximum pulse width of 2.3  $\mu$ s as seen by load capacitance of 11 pF, (2 probe capacitances not included)

#### 4. Summary

The 10 kV Pockels cell driver is EOSO's latest development in high voltage, high frequency and fast switching power supplies. The module as shown in Figure 6, has been developed to safely and reliably provide the high voltage switching required to drive the latest Pockels cells in high power Laser applications.



**Fig. 6:** 10 kV Pockels cell driver in a compact aluminium box that can be placed directly adjacent to Pockels cell to ensure best performance (leads run from the back of the box)

Max. input power requirements	+24 V/3 A
Typical output quarter wave voltage range	< 9000 V (see Fig. 5)
Rise and fall time (20 % - 80 %)	< 11 ns (see Fig. 4)
RMS jitter	< 500 ps
Pulse width	80 ns – 2.3 $\mu$ s
Maximum repetition rate	< 2.4 kHz
Load capacitance	$\leq$ 12 pF
Size (length x height x depth) cm	35 x 12 x 25
Monitor output	Pulse width TTL @ 50 $\Omega$
Trigger input	TTL

**Table 1:** Technical Specifications